

Deadweight Tester CPB5000 Pressure Balance - Primary Standard for Pressure

- Ranges up to 100 bar / 1500 psi: pneumatic operated
- Ranges from up to 1000 bar / 15000 psi: hydraulic operated
- Accuracy (total uncertainty of measurement) up to $\pm 0.008\%$ of measured value
- A basement can be fitted with individual measuring systems (piston-/cylinder-units). Fast and safe replacement of the measuring systems (with spanner, optional no tools needed)
- Self-sustaining complete system, also suitable for on-site measurements / calibrations
- Including Certificate of Calibration, traceable to National Standard (optional: DKD certification)



Deadweight Tester (Pressure Balances) are the most accurate instruments for the calibration of electronic or mechanical pressure measuring instruments. The direct measurement of pressure, according to its definition as a quotient of force and area, and the use of high-quality materials result in small uncertainties of measurement and an excellent long-term stability of five years. For these reasons, deadweight testers have already been used in calibration laboratories of industry, national institutes and research labs for many years. Due to the integrated pressure generation and the purely mechanical measurement principle, the **CPB5000** deadweight testers are ideally suited for on-site use as well as service and maintenance purposes.

The concept for a customised **CPB5000** assembly enables you to set up a compact complete system at a favourable price, consisting of an universal basement and the measuring systems (piston-/cylinder-units). The high-quality sensitive piston-/cylinder-systems are well protected in a special housing. Fast and uncomplicated changes of the measuring range are possible using a flat spanner, optional without having to use any tools.

The core of the **CPB5000** is a piston-/cylinder system of tungsten carbide. Besides this high-quality material, which primarily stands out for its small temperature coefficient, the workmanship of the system is a measure of the final accuracy of the pressure balance. Several refinement processes ensure a high-quality and even surface with small gaps of only a few micrometer. In order to generate the individual test points, the piston-/cylinder system is weighted with mass-loads, which are also calibrated and specially adapted to the respective application.

Depending on the measuring range of your device under test you can fit the instrument basement with the corresponding piston-/cylinder system. At the hydraulic models, the pressure is set via an integrated pump. The pneumatic models require an external pressure supply, if pressures > 10 bar / 150 psi are needed. The pneumatic models are supplied with control valves. For fine adjustment an adjustable volume with precision spindle is supplied. The weight applied is proportional to the desired pressure and provided by using optimally graduated weights. As soon as the measuring system reaches equilibrium, there is a balance of forces between pressure and wheel weights. Due to the excellent quality of the system this pressure remains stable over several minutes, so that for instance adjustments of your device under test can be carried out without any problems.

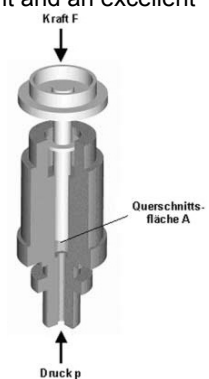

Intelligent Calibration Module type IKM

Especially when highly accurate measuring values with uncertainties of measurement of less than 0.025% are required, complicated mathematic calculations and corrections used to be necessary. With this optional addition to the system all critical ambient parameters are registered and automatically corrected. Furthermore, a calibrator function for pressure transmitters is integrated, so that a voltage can be supplied to the sensor and the sensors signals can be measured without any problem. See datasheet "IKM".



More optional Accessories:

- Set of trim-masses for generating intermediate values (Weights 1 mg to 50 g)
- Oxytester (Purifier) for measuring instruments where the filling medium should not come into contact with the pressure balance
- Dirt trap for test objects that are very dirty in order to avoid the penetration of dirt particles into the deadweight tester
- Set of adapters in a tool case with 5 most commonly used threaded adapters and a spanner (flats 32 and flats 14).



Included in standard Supply:

- Basement with protective cover, adjustable feet and water level
- Inlet pressure priming pump and spindle pump
- Clamp for specimens
- One piston-/cylinder system
- Set of st.st. weights in carrying case
- 1 litre special oil (for hydraulic models)
- Operating Manual
- Calibration Certificate (optional: DKD)



DRUCK & TEMPERATUR Leitenberger GmbH

Bahnhofstr. 33 • D-72138 Kirchentellinsfurt • Germany

Tel.: +49 - 71 21 - 9 09 20 - 0 • Fax: +49 - 71 21 - 9 09 20 - 99

E-Mail: DT-Export@Leitenberger.de • <http://www.druck-temperatur.de>



Dimensions in mm

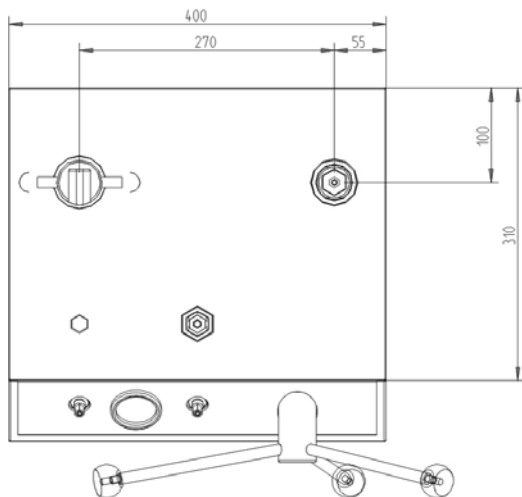
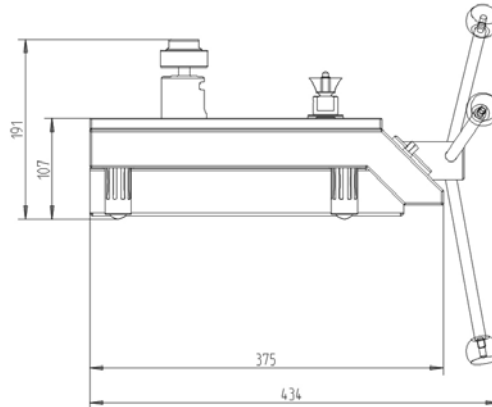
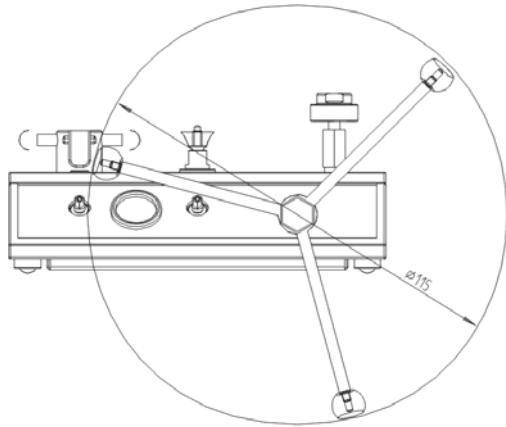

Adapter für Prüflingsanschluss

Adapter for specimen connection

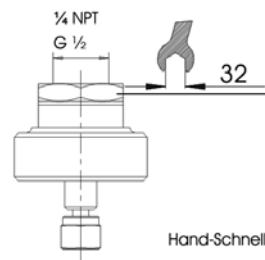

Hand-Schnellspanverschluss mit Gewindeeinsätze

Manual quick-connection clamps with threaded adapters

Available Pressure Ranges:

Pneumatic Models suitable for dry and clean air or nitrogen (for other media available on request)		Hydraulic Models suitable for operating fluid CPB5000-FLUID (1 L included) (for other media available on request)	
Range [bar]	Range [psi]	Range [bar]	Range [psi]
-0.03 ... -1 (Vacuum)	-0.435 ... -14 (Vacuum)	0.2 ... 60	
0.03 ... 2	0.435 ... 30	0.2 ... 100	2.9 ... 1000
0.2 ... 10	2.9 ... 150	1 ... 250	14.5 ... 5000
0.4 ... 50	5.8 ... 500	1 ... 400	29 ... 10000
0.4 ... 100	5.8 ... 1000	2 ... 600	29 ... 15000
	5.8 ... 1500	2 ... 1000	

Accuracy (uncertainty): Two versions available: $\pm 0.015\%$ or $\pm 0.008\%$ of measured value. The accuracy is characterised by the deviation span, which is the sum of the systematic error and the uncertainties of measurement. Longterm stability is not taken into account. Please note that corrections might be required if the instrument is used without the optional Intelligent Calibration Module IKM - see operating manual.

Other Models:

For high pressure up to 4000 bar / 60000 psi: see datasheet CPB5000-HP

For differential pressure calibration: see datasheet CPB5000-DP



DRUCK & TEMPERATUR Leitenberger GmbH

Bahnhofstr. 33 • D-72138 Kirchentellinsfurt • Germany

Tel.: +49 - 71 21 - 9 09 20 - 0 • Fax: +49 - 71 21 - 9 09 20 - 99

E-Mail: DT-Export@Leitenberger.de • <http://www.druck-temperatur.de>

